



Features

- Reliable, robust and electronically controlled QSB series Cummins engine, fulfils Level 3A of the international exhaust emission standard.
- Energy-saving compressor screw block machined with smallest tolerances, progressive volume flow. Regulation: Engine speed and air intake regulation are automatically adapted to compressed air requirement.
- Precompression of compressor intake air with intermediate cooling by means of second exhaust gas turbocharger.
- Increase in overall efficiency of the engine by 14%.
- Corrosion resistant, galvanised canopy sheet metal with lasting baked powder coating.
- Quick replacement of the individually bolted canopy panels, e.g. in case of accidents.
- 4 large and wide-opening front and side wing doors with robust gas struts ensure easy access for maintenance.
- Large fuel tank with 370 l [81.4 gal] capacity.
- Start with key-operated switch.
- Individual indicators for automatic safety cut-out in case of malfunction.
- Automatic cut-out for engine oil pressure, engine cooling water and compressor temperature, cooling water level, load control and Water in fuel pre-filter
- Standard pre-filter prevents pollution.
- Oil temperature control valve for very low ambient temperatures incorporated as standard.
- Central lifting eye for easy handling by crane.

Benefits

- **The smallest and lightest in their performance class**
for universal use due to their many options and various pressure variants.
- **Large fuel savings thanks to innovative patented system**
Fuel saving of up to 20 % of lifetime costs by second engine exhaust turbo.
- **Large control range 1000–2400 r.p.m.**
Equals 58 % of continuous control via speed change, this value is not achieved by any conventional compressor. As a result, control is very exact and precise and allows great fuel savings in partial load operation.
- **Eased engine starting and automatic cut-out**
Protects the engine / extends its lifetime.
- **Operation from –15°C to +50°C ambient temperature and at 5000 m [16400 ft] (a.s.l.) at 30°C ambient**
Significant reliability.
- **Tandem chassis**
Best manoeuvrability and stable.
- **Operating weight below 3500 kg [7716 lb]**
Thus also towable by vans and jeeps.
- **German-TÜV – testing only every 2 years**
Because of low operating weight, saves time and money.
- **Only requires parking brake**
Robust and simple, no complicated pneumatic brakes with ABS necessary.
- **8 automatic cut-out functions**
Protect engine and compressor.
- **Maintenance points on one side**
Easily and quickly accessible.
- **Screwed on individual panels with detachable insulating mats**
Economical and quick replacement.
- **Hot galvanised chassis with individual adjustment**
Long lasting and universally usable.

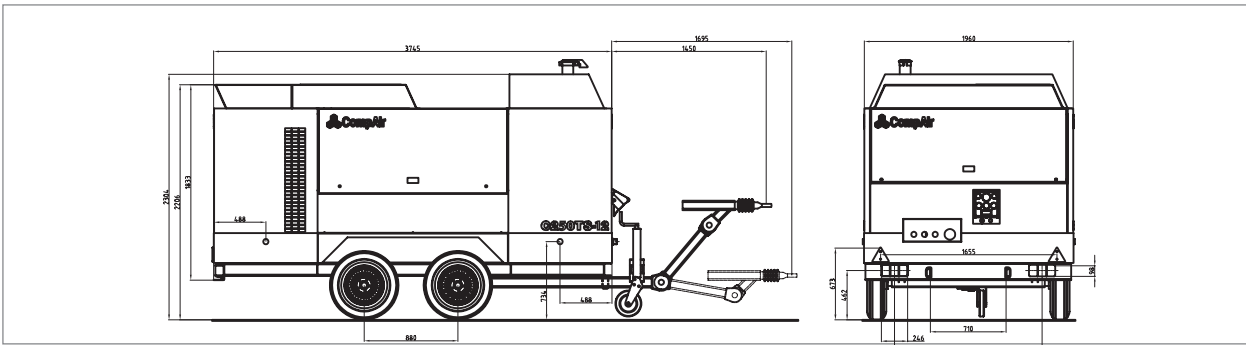

Technical Data	DLT 27 01				Options
Type	DLT 27 01				<ul style="list-style-type: none"> <input type="radio"/> Built-in aftercooler with automatic condensate separation. Reduces the moisture content in the compressed air. Additionally followed by built-in air re-heater using the heat of the compressor oil. <input type="radio"/> Built-in microfilter combination (in addition to above mentioned aftercooler) Air treatment with microfilters to ISO 8573.1 standards including ZTV-SIB 90 with residual oil content of < 0.01 ppm. <input type="radio"/> Base mount Bas-mount design for fixing to the loading deck of a truck. <input type="radio"/> Skid mount Skid-mount design with forklift openings for placing on the ground. <input type="radio"/> Special paint colour with customer adhesive vinyl Provides distinctive site identity and assists in traceability in the event of loss or theft. <input type="radio"/> Engine overspeed shutdown valve An overspeed valve in the engine inlet port ensures immediate shutdown in the event of ingestion of inflammable gas to prevent damage from overspeeding engine. <input type="radio"/> Exhaust spark arrestor Safe operation also in difficult areas like refineries etc. <input type="radio"/> Cold start aid Enables reliable starting also at ambient temperatures of minus 30 °C.
Trade name	C 240 TS-14	C 250 TS-12	C 260 TS-10	C 270 TS-9	
Operational data					
Volume flow (m ³ /min) [cfm] ¹⁾	24 [847]	25 [882]	26 [917]	27 [953]	
Operating pressure (bar) [psi g]	14 [204]	12 [175]	10 [145]	8.6 [125]	
Operating pressure range (bar) [psi g]	5–14/12/9 [73–204/175/131]				
Oil capacity compressor (l) [gal]	65 [14]				
Engine					
Drive engine/Engine model	Cummins QSB 6,7				
Cooling system	water cooled				
Installed engine power (kW) [bhp]	228 [307]				
Speed range (rpm)	1000–2400				
Oil capacity engine (l) [gal]	15 [3.3]				
Fuel tank capacity (l) [gal]	370 [81.4]				
Coolant Capacity (l) [gal]	70 [15.5]				
Weights/Dimensions					
Operating weight, braked, adjustable towbar (kg) [lb] ²⁾	3340 [7363]				
Allowable total weight (kg) [lb]	3500 [7716]				
Length braked, adjustable towbar (mm) [in]	min 5195 [205] – max 5440 [215]				
Length of canopy (mm) [in]	3750 [148]				
Width (mm) [in]	1960 [77]				
Height (mm) [in]	2350 [93]				
Compressed air outlets	3 x 3/4" + 1 x 2"				
Sound levels					
Power sound level (dB(A)) acc. to 2000/14/EC ³⁾	100				
Pressure sound level (dB(A)) acc. to PNEUROP at 7 m ⁴⁾	71				
¹⁾ Acc. to ISO 1217 Ed. 3 1996 Annex D ²⁾ Without options ³⁾ Legal limiting values of EC directive ⁴⁾ PN8NTC2.2					



www.compair.com

