

Transcube tank and bund are fabricated from 3mm mild steel to a quality standard ISO9001:2000.

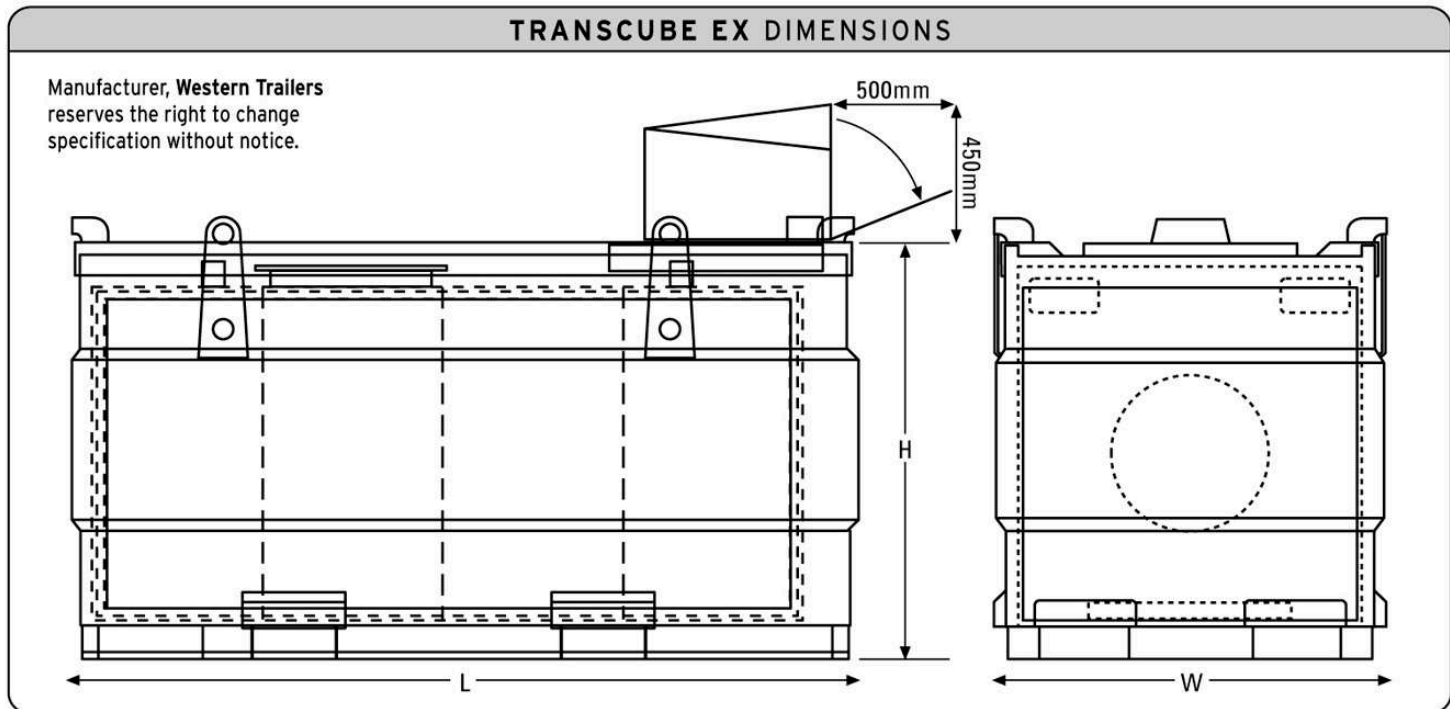

**TRANSCUBE EX SPECIFICATION CHART**

	MODEL NO.	CAPACITY		DIMENSIONS			WEIGHT	
		Litres	Gallons	L	W	H	Unladen	Laden
	10TCEX	960	210	1260mm	1150mm	1310mm	576kg	1439kg
	20TCEX	1966	432	2300mm	1150mm	1310mm	845kg	2644kg
	30TCEX	2944	648	2300mm	1630mm	1310mm	1075kg	3725kg

**TRANSCUBE EX OPTIONS**

	<b>TCEX HOOD</b> Pump hood required for electric pump options: EH12VFPFM, EH24VFPFM, EB12VFPFM, EB24VFPFM, EB240VFPFM, EB110VFPFM and filter WPFFC.		<b>MHFP</b> - Manual diaphragm hand pump c/w 4mtr delivery hose and trigger nozzle.
	<b>EH12VFPFM</b> - 12v 70l/min self-priming pump c/w filter, K33 flow meter, 4mtr delivery hose and auto shut off nozzle. <b>EH24VFPFM</b> - as above with 24v.		<b>3/8F+RNRV</b> - 3/8" fuel feed and return tank bulkhead fittings c/w 1/2" valves, foot valve and strainer.
	<b>EB12VFPFM</b> - 12v 40l/min self-priming pump c/w filter, K33 flow meter, 4mtr delivery hose and auto shut off nozzle. <b>EB24VFPFM</b> - as above with 24v.		<b>1/2F+RNRV</b> - 1/2" Fuel feed and return tank bulkhead fittings c/w 1/2" valves, foot valves and strainer.
	<b>EB240VFPFM</b> - 240v 45l/min self-priming pump c/w filter, K33 flow metre, 4mtr delivery hose and auto shut off nozzle. <b>EB110VFPFM</b> - as above with 110v.		<b>1/2F+R</b> - 1/2" Fuel feed and return tank bulkhead fittings c/w 1/2" valves.
	<b>EB12VFP</b> - 12v 40l/min self priming pump c/w 4mtr delivery hose and auto shut off nozzle. <b>EB24VFP</b> - as above with 24v. (fitted on flat lid option).		<b>1/2OFT90</b> - Overfill prevention thermistor.
	<b>WPFFC</b> - Water and particulate removal 30 micron nominal filter for hood electric pump option only.		<b>STANDARD COLOURS</b> RAL 1028 (Yellow) RAL 9001 (White)
			<b>COLOUR OPTIONS</b> Red, Green, Blue, Grey, Black, Silver

**TEL: +44(0)1179528989**



**Your diesel fuel transported and deployed quickly, legally and safely...**



**TEL: +44(0)1179528989**  
22 The Green - Stoke Gifford - Bristol - BS34 8PD - UK  
TRANSCUBE is a registered trademark. ©WESTERN TRAILERS 02/05

**TRANSCUBE**

**WESTERN TRAILERS**  
**ENVIRONMENTAL**  
**WESTERN**

